

Atwell

self-adhesive **Labellers**

AL120S

High Accuracy Programmable Label Head



- A** *Reliable, consistent labelling*
- A** *Accuracy to $\pm 0.25\text{mm}$ using heavy duty stepper motor*
- A** *Standard Key Lock Security Access*
- A** *25 easily stored programmable label settings for quick recall and reduced changeover time*
- A** *Variable speed to 40 metres per minute*
- A** *Operator friendly display panel with direct function access touch buttons*
- A** *Remote mounted metal control box with wipe clean control panel*
- A** *Encoder for speed following of wrapping machines*
- A** *Choice of hot foil or thermal in line coders for Use By Dates, Batch nos, Bar codes etc*
- A** *Top, Side or Bottom mounted*
- A** *Left or right hand versions*

U grow it...
...we'll label it

Fast, Reliable and Easy to use
Semi Automatic and Bespoke Fully
Automatic Labelling Systems

U pick it...
...we'll label it

Fast, Reliable and Easy to use
Semi Automatic and Bespoke Fully
Automatic Labelling Systems

U sell it...
...we'll label it

Fast, Reliable and Easy to use
Semi Automatic and Bespoke Fully
Automatic Labelling Systems

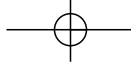

Technical Specification

- Speed:Variable 1-40m/min
- Motor:Stepper motor, microprocessor controlled
- Label width:Max 120mm or 200mm
- Min. label size:15mm x 15mm
- Label Detection:.....Fixed fork p.e. cell or clear label sensor
- Label Roll:300mm diameter
- Label core:.....45mm or 76mm ID
- Electrical supply:.....220/240V. AC 50/60Hz
- Memory capacity:25 labels stored with Alpha/Numeric display
- Weight:Approx 14kg excluding control box

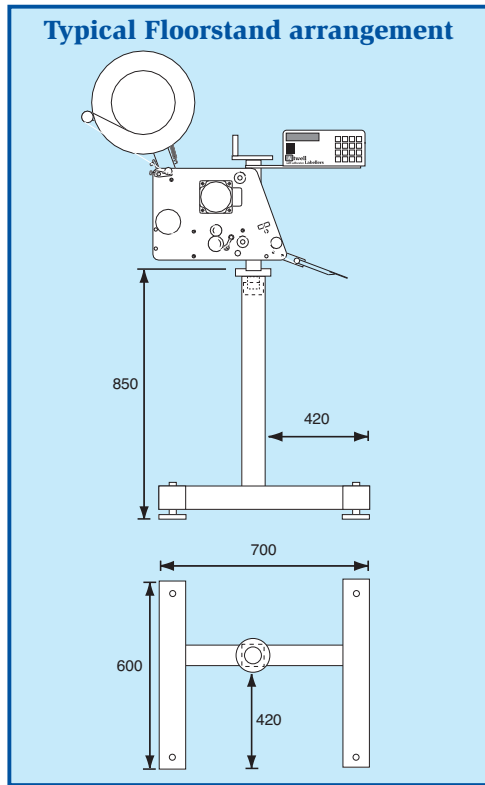
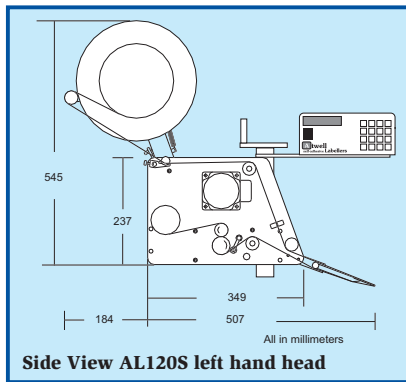
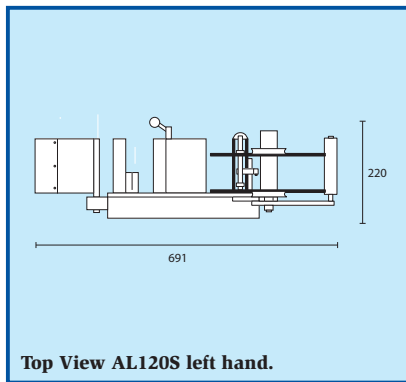

Options:

- Max 76m/minute linear speed
- Encoder for automatic speed following/ label position
- 50 label programmable memory
- End of roll alarm/Warning light
- Blow-on unit
- Powered Dispensing Edge
- Hot foil or Thermal printers
- Bar code and vision system interface

Full range complete labelling systems for Wrapround, Front & Back, Top and Top/Bottom, Print and Apply requirements. Cross Web labellers, Film Labellers, Bespoke specialist applications.

Atwell
self-adhesive **Labellers**

Unit 18, Bolney Grange Business Park
Stairbridge Lane, Hickstead
West Sussex RH17 5PB ENGLAND
Tel 01444 239970 Fax 01444 246609
E sales@atwell-labellers.co.uk W www.atwell-labellers.co.uk

As part of our continuing policy of improvement we reserve the right to change this specification without notice.

LITAL120S

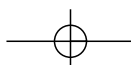

U pack it...
...we'll label it

Fast, Reliable and Easy to use
Semi Automatic and Bespoke Fully Automatic Labelling Systems

U fill it...
...we'll label it

Fast, Reliable and Easy to use
Semi Automatic and Bespoke Fully Automatic Labelling Systems

U make it...
...we'll label it

Fast, Reliable and Easy to use
Semi Automatic and Bespoke Fully Automatic Labelling Systems

