



Beverage

Aptar 
food + beverage



DELIVERING SOLUTIONS, SHAPING THE FUTURE





The Markets We Serve

Bottled Water

Juices

Functional Drinks



RTD Tea & Coffee Concentrates Dairy





From Project to Production

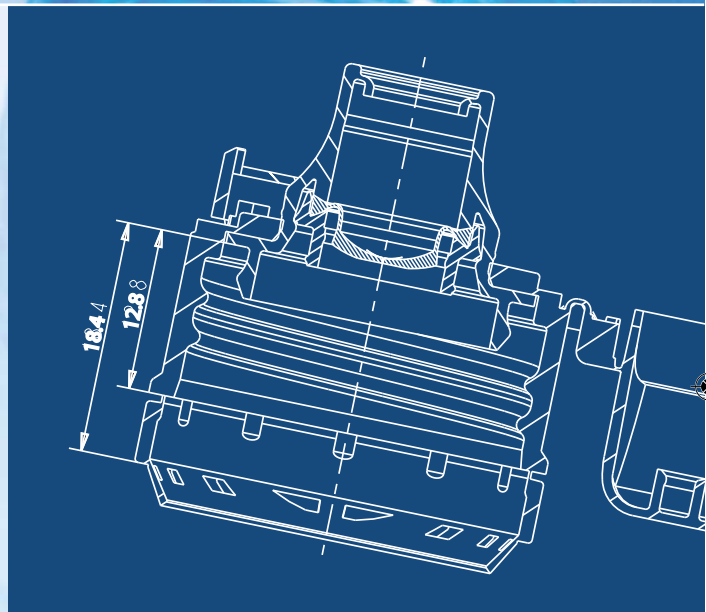

Key Factors to Ensure Market Success



Innovation

Market Knowledge

Design & Development

Project Management

Production

Speed to Market

Resources to meet your needs

- 50 operating facilities in 19 countries
- Global Beverage Expert Centre
- Dedicated designers and project managers
- In-house mould design and building



North America

Sales + Operations

Latin America

Sales + Operations

Global

Business Development

• Food + Beverage
Production Sites

Quality Processes

ISO 9001, BRC IOP, HACCP
Internal Laboratory Testing





Market Knowledge

From the start of a project, innovation is backed by sound market knowledge.

Industry requirements and market trends are important factors in any brief.

We are active members of the following industry organisations :

CETIE, ISBT, BSDA.

Partnerships with resin and filling line suppliers enable us to apprehend a project in its globality and have furthered the development of organoleptic resins and aseptic filling for sports caps.



Safe
Convenient
 Easy to Open
Fun Robust
Hygienic
 Environmentally
 - Friendly
Intuitive
Functional

Consumer Expectations

Consumer testing enables us to obtain a precise idea of consumer expectations. Our products bring increased convenience to the end user and added value to our customers.

Caring for the Environment a special beverage valve

We have developed a specific valve for beverage which respects the PET recycling stream.



Consumer-preferred



"This closure is great for sports - makes drinking fun."

"It has a good hinge which doesn't get in the way when I drink."



"Safe for my children - no loose overcap."

*"The drink flows easily."
"I can put it in my bag and it won't leak."*



"Easy to open and snap shut."

"The spout feels comfortable to drink from."



Standard Beverage Closures



The Original

- 28mm PCO/BPF
- 30/25
- 1881

Available with
SimpliSqueeze®
beverage valve

SimpliDrink

- 28mm(PP)
- 30/25 (PP & PE versions)
- 38 mm 2 thread (PP)

liner capable
Available with Simpli-
Squeeze® beverage valve

Syrup

- 38mm (PE)
- 3 start thread
- Pull ring TE
- Pouring Beak

38mm Linerless Hotfill

- 3 start thread

Custom Solutions on Demand



Your Partner for Success in the Beverage Market

Europe

Aptar Food + Beverage
D 94078 Freyung Germany
00 49 (0) 8551 975 234

North America

Aptar Food + Beverage
IL 60014 USA
00 1 815 261 3217

Latin America

Aptar Food + Beverage
Mexico CP 76240
00 52 (33) 3628 1938

Asia

Aptar Food + Beverage
PR China 215123
00 86 512 6260 2555

Aptar Food + Beverage is part of the Aptargroup family of companies, along with Aptar Beauty + Home and Aptar Pharma. We create innovative dispensing systems for leading food and beverage manufacturers. With a wide range of dispensing solutions and broad geographic presence, we help our customers stay ahead of the ever-changing demands of consumers around the globe.

Printed on PEFC



paper

infobevctl@aptar.com

www.aptar.com