

Option 3 Depositor / Filling Machine

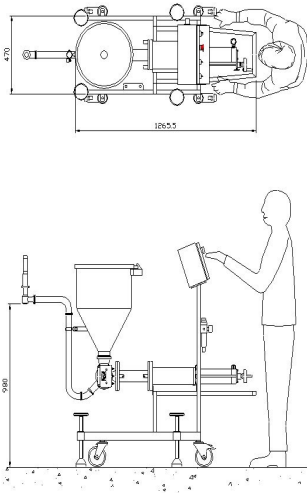

Mini-Fill

Standard-Fill

Maxi-Fill

Pump Bore	Deposit Range	Pump Bore	Deposit Range	Pump Bore	Deposit Range
Ø26 x 150mm	3ml - 75ml	Ø38 x 160mm	10ml - 170ml	Ø130 x 205mm	200ml - 2500ml
Ø32 x 150mm	5ml - 110ml	Ø58 x 160mm	25ml - 400ml	Ø130 x 250mm	200ml - 3300ml
Ø38 x 150mm	10ml - 160ml	Ø71 x 160mm	50ml - 600ml	Ø165 x 250mm	500ml - 5000ml
		Ø101 x 160mm	125ml - 1200ml		

- Designed for food manufacturers using conveyor filling lines
- Provides highly accurate, damage free depositing of liquid, semi-liquid and suspended solid products such as honey, preserves, condiments, sauces, dressings, soup, dips, sandwich fillers, yoghurt, dessert, cake, pudding and ready meal ingredients
- Utilised as an automatic conveyor filling machine or a semi-automatic, stand alone depositor
- Pneumatically operated, requires compressed air supply
- Mobile with lockable castors
- Low level 40 litre product hopper
- Choice of mini, standard or maxi-fill pump barrels
- "Single" deposit range of 3ml - 5000ml
- Choice of depositing nozzles / decorating heads
- High quality, robust construction using 316 food grade stainless steel
- Fully adjustable depositing volumes and operating speeds
- Compact, versatile, operator friendly
- Hygienic, easy to clean, quick to strip down, simple to maintain
- Available for outright purchase, short or long term hire, no-obligation on site trial
- Comprehensive guarantee and full after sales support
- Designed and built in-house at our Lancashire factory