

# FULLY AUTOMATIC END LOAD CARTONER



[www.tfreemantle.com](http://www.tfreemantle.com)



## FUNCTION

Product is loaded into the machine's infeed conveyor either manually or automatically. The machine detects the products and automatically selects and erects a carton from the carton magazine. The product is then automatically loaded into the opened carton and the carton is folded, glued and sealed. The finished product is then ejected from the end of the machine via edge leading. The fully automatic machine can be supplied complete with an integral product transfer system to accept random supply of product from the line and feed directly into the machine.

# FULLY AUTOMATIC END LOAD CARTONER

## Technical Details

**Electrical requirements** Supplied with a 3 metre armoured cable complete with 2P+Earth 16 amp plug for connection to a single phase 16 amp supply

**Compressed Air** Supplied with filter regulator with 8mm push in fitting for connection to 80psi/5.5 bar compressed air supply

**Lifting weight** 1,250 kilos. Ideal lifting points marked for fork truck offloading

Alternative specifications available for worldwide installations

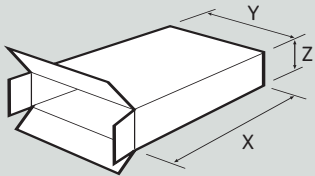
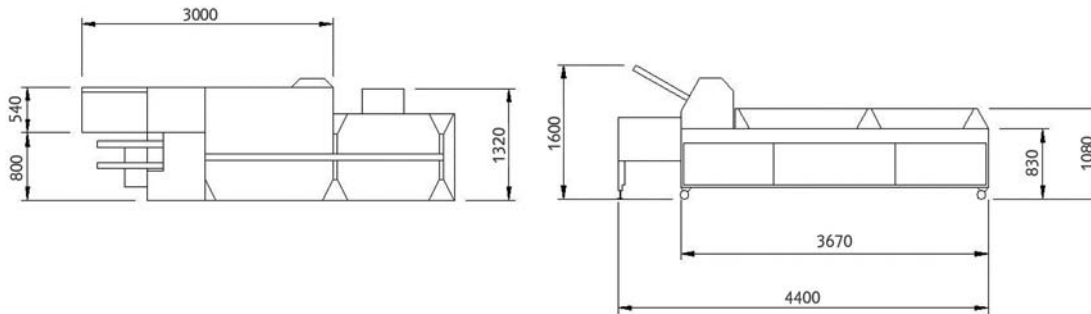

Capable of speeds up to 200 cartons per minute (subject to machine type)

Fully adjustable for a wide range of carton sizes

X - 110 to 250mm

Y - 50 to 225mm

Z - 20 to 80mm

Other sizes not shown can be run with modification (subject to quotation). Restrictions apply to certain combinations of sizes.



## MAIN FEATURES

- Quick and simple size change that can be completed in less than 15 minutes
- Unique slim line design to take up much less floor space
- Fitted with the glue jet applicator unit to give the cleanest and most efficient glue application available
- Unique product chute to ensure smooth loading of a wide range of product types
- Variable speed
- Low carton detection with timed warning beacon
- Built to stringent quality control procedures to ensure customer satisfaction
- Full 24v safety interlock system to give easy access to the machine while being safe and simple to use
- Pressure regulated product loader for gentle feeding of delicate products
- Simple and easy to understand machine controls
- Available with a wide range of options and specifications to suit individual customer requirements

"We have built our reputation on a number of core values - quality, reliability and innovation. The experience of our technical engineers and their focus on customer satisfaction has created a product range that is simple, robust, hygienic and can be applied to most sectors including food, cosmetics, household goods and healthcare."

Designers & Manufacturers of  
Fine Quality Packaging Machinery



**T.FREEMANTLE LIMITED**  
Atkinson Way, Foxhills Industrial Park  
Scunthorpe, DN15 8QJ UK

**T** +44 (0)1724 276908  
**F** +44 (0)1724 276909  
**E** sales@tfremantle.com